



SMART LITE Retail

AdBlue® Retail solution for your trucks, vans & passenger cars

Description

GreenChem offers a smart solution designed for AdBlue® RETAIL storage and dispensing equipment to serve passenger cars, trucks and vans. The only quality AdBlue® bulk storage and dispensing tank range designed and built by an AdBlue manufacturer. The small footprint design makes it possible to install the system in the smallest of places: directly on a service station island with limited space or any other location where AdBlue can be offered.

The SMART Lite system is available with several options and extensive branding opportunities.

We can offer an “all inclusive” solution with no start up fees or capital expenditure and as always, with a fully integrated telemetry system for automatic deliveries.



Technical Characteristics

- ▶ Power system: Single phase 230V 50Hz 10A
- ▶ Dimensions (mm): 1520 x 1300 x 2420 (L x W x H)
- ▶ Armoured cable: 5 metres
- ▶ Shipping weight: 315kg
- ▶ Inner tank capacity: 2300 litres
- ▶ Hose: 3.8 metres (19 mm inner diameter)
- ▶ Roof opening for easy maintenance
- ▶ Bund wall material: HDPP with lifting points
- ▶ Submersible pump, control panel and high level alarm
- ▶ Run-dry protection
- ▶ Dry break 2” TODO coupling
- ▶ MID certified flow metre & electronic
- ▶ Standard communication protocol TATSUNO IPE
(Other protocols available on request).



System options

- ▶ ZVA automatic nozzle: Passenger car or truck
- ▶ Dual side system (2 hoses / 2 nozzles / 1 display)
- ▶ IR manager remote control

Benefits

Design

- ▶ No risk of product contamination
- ▶ Safe, durable and corrosion free AdBlue® storage
- ▶ Small footprint design
- ▶ Manufactured according to ISO 22241, 9001:2015 and 9001:2015 standards
- ▶ Stainless steel piping and connections

Functionalities

- ▶ Weights & Measures MID certified commercial solution
- ▶ Installation for Service stations with direct connection to POS
- ▶ Fully bunded system with level and overfill alarm for optimum leak protection

Commercial

- ▶ Quality AdBlue® always available thanks to automatic deliveries managed by telemetry
- ▶ Minimum civil works





System dimensions

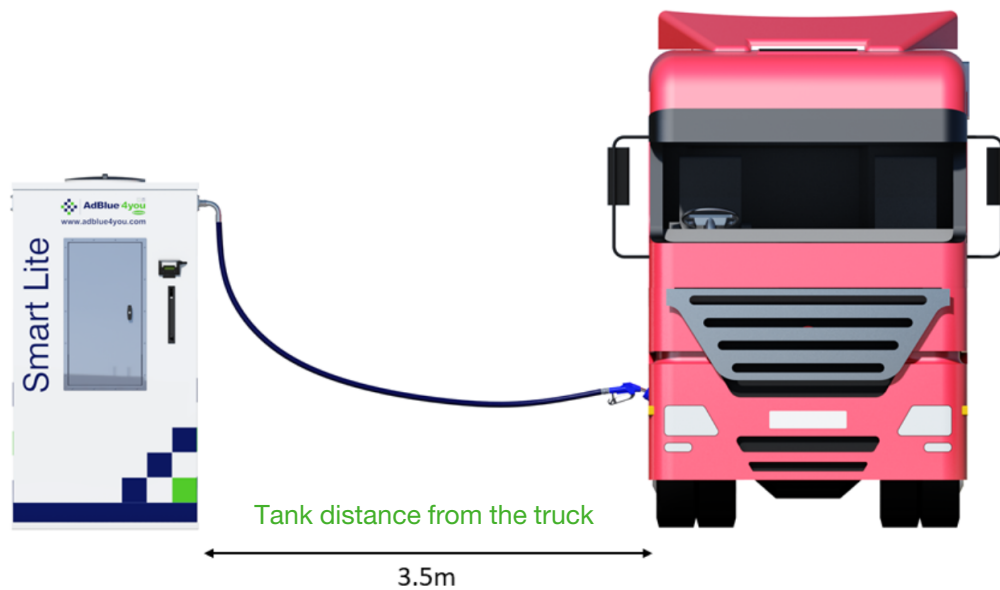
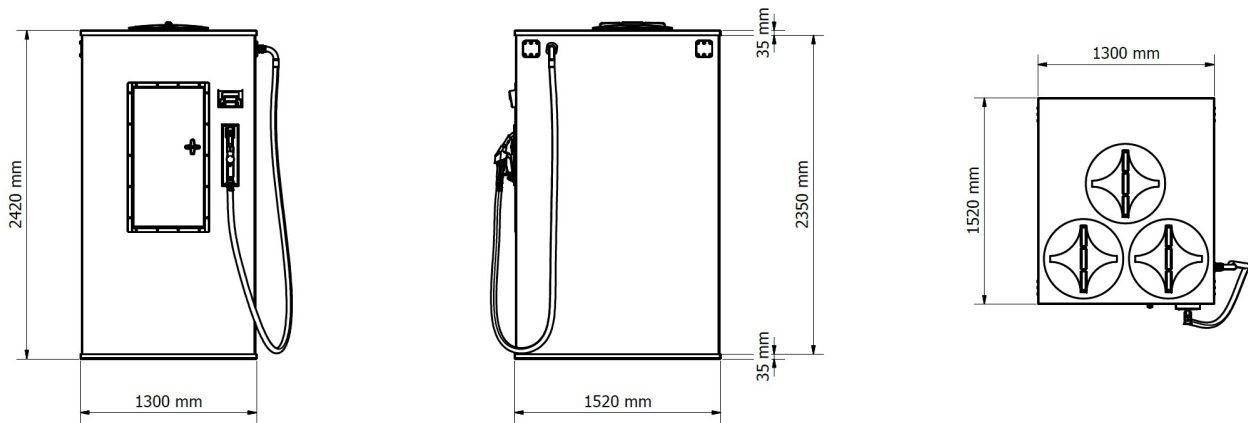

Belgium | Brazil | Czechia | France | Hungary | Italy | Netherlands | Poland | Slovakia | Spain | United Kingdom

GreenChem Solutions LTD
 Suite 3 Midshires House, Midshires
 Smeaton Close AYLESBURY
 HP19 8HL, The United Kingdom

Contact Information

Tel. +44(0)1296 678 548
 uk@greenchem-adblue.com
 www.greenchem-adblue.com



GreenChem

ISO 22241
 ISO 9001 : 2015
 ISO 14001 : 2015

